

# KOMATSU<sup>®</sup>

## S132

Forestry Quality™

S132

HARVESTING HEAD



## Effective, flexible and reliable in all kinds of forests

The new Komatsu S132 isn't just an extremely flexible and adaptable head. It's also superbly reliable and efficient even in the most difficult forests. Important explanations for these properties are the head's basic design (two-wheel fed) and the knife control, Flex Friction Control. With Flex Friction Control, the trunk's position in the feed line is regulated with a sensor in the vertical knife. The result is low friction without sacrificing delimiting quality. Explanations behind the operational reliability range from the robust construction with a frame in high strength steel to smart hose routings and protected head components, such as the head computer.

Significant productivity benefits include the powerful

tractive force and the effective delimiting with three hydraulically operated delimiting knives and a fourth moving vertical knife. Service friendliness is seen most of all in the good accessibility to service points, valve assemblies and other important components.

Moreover, all of these benefits can be adapted to your specific needs. Options and customisation capabilities encompass everything from measurement, feed rollers and the cutting unit to colour marking, stump processing and multi-tree equipment. So if you want a head that delivers in all kinds of forest, and precisely in accordance with your needs – choose the new Komatsu S132.

## TECHNICAL DATA

### Komatsu S132, highlights

- Two-wheel feed that maximises productivity in all kinds of forests
- Three hydraulically operated delimiting knives and a fourth moving vertical knife. Stationary delimiting knife mounted above the saw box for delimiting low branches
- With Flex Friction Control, knife pressure and lifting force are controlled by sensors in the vertical knife to produce the least possible friction between trunk and head
- Easy service and maintenance with optimal access to all vital parts
- Smart hose routing that minimises downtime
- Well-protected head computer mounted under head hood
- Option of equipping the head with either manual or automatic chain tensioning
- Choice of feed rollers for maximum adaptation to customer needs
- Multi-tree equipment, colour marking and stub processing as options
- Optional extra measuring point for increased measurement accuracy
- Robust construction, frame in high strength steel

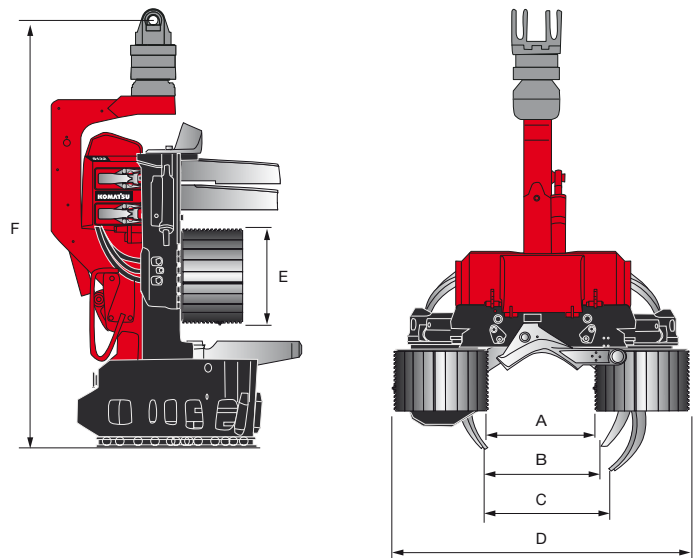

Weight (dry weight):	from 1,364 kg
Feed rate (motor dependent):	0–5 m/s
Feed force, gross (motor dependent):	28.7/31.1 kN
Feed wheel type:	Steel rollers
Delimiting knives, max. amount:	4
Delimiting dia., tip-to-tip:	428 mm
Saw bar:	82.5 cm
Saw motor:	19 cm <sup>3</sup> /rev.
Felling diameter, theoretical max:	720 mm
Requisite max. hydraulic flow:	320 l/min
Requisite max. hydraulic pressure:	28 MPa

<b>A</b> Roller opening, max.	625 mm
<b>B</b> Opening front knives, max.	641 mm
<b>C</b> Opening rear knife, max.	690 mm
<b>D</b> Width, max.	1,689 mm
<b>E</b> Roller diameter	532 mm
<b>F</b> Height with rotator	2,134 mm

NB: Refers only to one of several possible configurations and the head's weight is dependent on equipment options.

### EQUIPMENT OPTIONS

Standard and extra equipment are market-dependent and vary between countries. Your sales representative has an up-to-date list of what is included.

Technical data/dimensions vary depending on optional equipment selected. Specifications and designs are subject to alteration without prior notice. Photos, diagrams, and figures do not always show the standard configuration.



### ZONE OF APPLICATION

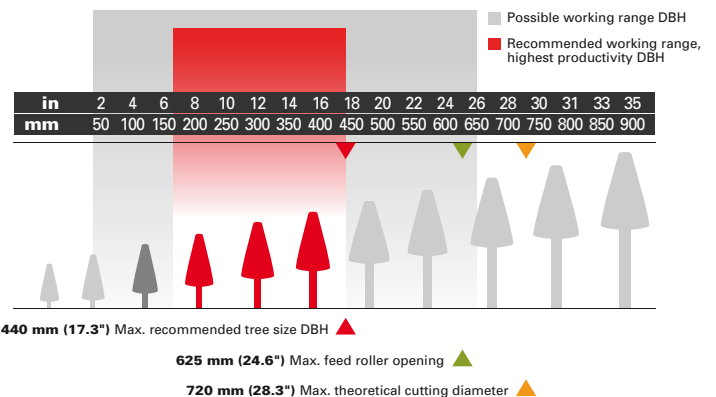

## KOMATSU

**Komatsu Forest AB**  
www.komatsuforest.com